

Application Note

Load Management using the DGC-2020HD Load Shedding Functionality

The DGC-2020HD can implement sophisticated load management schemes through the Load Shedding feature. Load shedding functionality is presented herein along with some application examples. The

Load Shed function provides a way to manage up to 64 loads. Loads can be shed from the system in lowest to highest priority order with logic commands. Loads can be added back to the system automatically in priority order (reverse of shedding order) when sufficient online generation capacity becomes available. Loads can also be added to the system with logic commands.

Load Shed Settings

The settings for Load Shedding are on the Load Shedding screen in BESTCOMSPPlus® (Figure 1).

Load shedding interfaces to BESTlogic™Plus logic through Logic Status Inputs and Logic Elements. There are 64 Loadshed Priority Enabled status inputs (LOADSHED_PRIORITY1ENABLED through LOADSHED_PRIORITY64ENABLED), 64 Load Shed Priority Add logic elements (LDSHEDPRIORITY1ADD through LDSHEDPRIORITY64ADD), and 64 Load Shed Priority Trip logic elements (LDSHEDPRIORITY1TRIP through LDSHEDPRIORITY64TRIP). There are 16 Load Shed Bias Enabled logic elements (LDSHEDBIASENABLE1 through LDSHEDBIASENABLE16).

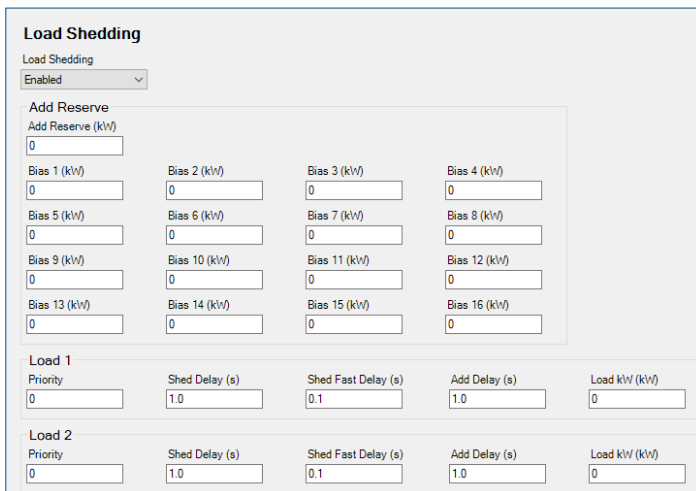
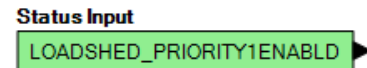

Figure 1 - Load Shedding Settings

Load Shedding, Priority X Load Enabled



True when a load is enabled.

Load Shedding, Load Add Demand Start

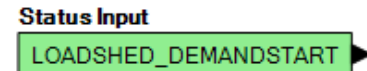

True when the currently generated reserve capacity is too low to add the next highest priority load, but sufficient offline generation capacity could be started to accommodate the load. In other words, this attempts to start more generators to pick up the load as long as enough generators exist in the system to meet the demand.

Load Shed Priority X Add

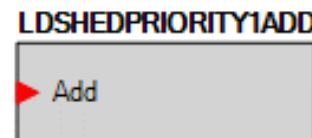

Force add of a particular load. If this input is held true, the load will not be shed any time the Shed Load or Shed Load Fast inputs are true. If this particular load were to be the next priority to shed, but the Load Add input is true, the next lowest priority will be shed instead. The Trip All input has priority over the Load Add inputs. The loads will always be tripped with the Trip All input even if the Load Add input is true.

Load Shed Priority X Trip

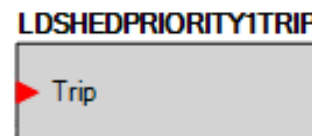

Force trip of a particular load. If this input is held true, the load will not be considered for addition back into the system regardless of the system reserve capacity. If this particular load were to be the next priority to add, but the Load Trip input is true, the next highest priority will be added instead. The Load Trip input has priority over the Add All input. The load will not be enabled if the Load Trip and Add All inputs are simultaneously true.

Load Shed

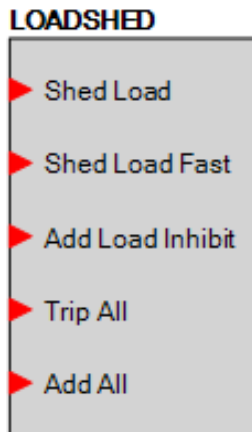

Shed Load: Begins shedding loads from the system starting with the lowest priority enabled loads. On the rising edge of the Shed Load input going true, the lowest priority load is immediately shed. Subsequent loads will be shed after each load's programmed Shed Delay setting if the Shed Load input continues to be held true. The first load is shed with no delay to provide immediate load relief.

Shed Load Fast: This input is the same as the Shed Load input, but uses the programmed Shed Fast Delay settings during timing. On the rising edge of the Shed Load Fast input going true, the lowest priority load is immediately shed. This is done regardless of the state of the Shed Load input.

Load Add Inhibit: This input prevents load from being added to the system. This can be used in cases where the system must operate at reduced generator capacity to prevent overloading the available machines.

Trip All: This input forces an immediate trip of all loads without time delay. If the Load Add Inhibit element is not held true, loads can begin sequencing back on from the highest priority load when this is removed. Note that loads with priority of 0 are disabled, and are not tripped when Trip All is true.

Add All: This enables all loads without time delay. The Shed Load, Shed Load Fast, and Trip All inputs have priority over this input to allow the load shed function to operate. Note that loads with priority of 0 are disabled, thus they are not enabled when Add All is true.

Load Shed Bias Enable X

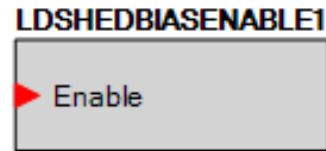

When true, the corresponding Add Reserve Bias value is added to the calculation for determining when to add a load. If multiple Load Shed Bias Enable elements are true simultaneously, the sum of all Add Reserve Bias values is added to the calculation.

Shedding Load

When the Shed Load input of the load shed (LOADSHED) logic element is true, loads with higher load priority numbers are shed first and their corresponding logic status inputs (LOADSHED_PRIORITY_N_ENABLED above) become false. A load priority with a number of zero (0) is disabled and excluded from load adding/shedding functions.

The first load is immediately shed and subsequent loads are shed after the duration of the Shed Delay. Loads are shed one at a time and the Shed Delay must elapse between iterations. The same process is followed when the Shed Load Fast input of the load shed (LOADSHED) logic element is true, except the Shed Fast Delay is used instead.

Adding Load

As available generators are brought online, the online kW capacity of the system increases. Load Add Reserve is used to determine when the Generation Reserve Capacity is sufficient to add a load back into the system. The Generation Reserve Capacity is the amount of generation reserve based on machine ratings from the currently running generators, defined in Equation 1:

$$\text{Generation Reserve Capacity} =$$

$$\sum \text{Online Gen Rated kW} - \sum \text{Online Gen Generated kW}$$

Equation 1 - Generation Reserve Capacity

where

$$\sum \text{Online Gen Rated kW}$$

indicates the summation of the rated kW of all machines presently running on the system, and where

$$\sum \text{Online Gen Generated kW}$$

indicates the summation of the Generated kW of all machines presently running on the system.

The next highest priority load can be added back to the system when the generation reserve capacity is large enough to accommodate the load kW plus the load add reserve. Let this be called the Load Add Level. The Load Add Level is calculated in Equation 2:

$$\text{Load Add Level} = \text{Load kW} + \text{Load Add Reserve} + \sum \text{Enabled Add Reserve Bias}$$

Equation 2 - Load Add Level

where

$$\sum \text{Enabled Add Reserve Bias}$$

indicates the sum of all of the enabled Add Reserve Bias settings.

When the Generation Reserve Capacity is greater than the Load Add Level for a time equal to the Add Delay period configured for that load, then the corresponding logic input (LOADSHED_PRIORITY_N_ENABLED, where N corresponds to the load number) becomes true. The true input can be linked to an output, which can in turn close the breaker to the corresponding load, thus adding it to the system. Loads with lower load priority numbers are added first, starting at one (1). A load priority with a number of zero (0) is disabled and excluded from load adding/shedding functions.

Up to 16 Add Reserve Bias values can be added cumulatively to the default Add Reserve value by enabling the corresponding load shed bias enable (LDSHEDBIASENABLE1-16) logic elements.

Operation of Multiple Loads with the Same Priority

Loads with the same priority setting are sub-prioritized in order based on shed delay, fast shed delay, then setting

index number. This guarantees a unique overall ordering even if multiple loads share the same priority setting. If the priority settings are the same between two loads, the load with the shorter Shed Delay is lower priority, i.e. it will be shed first. If the Shed Delays are also the same, the load with the shorter Shed Fast Delay is lower priority. If the Shed Fast Delays are also the same, the load with the lower setting index number is lower priority, e.g. Load 4 is lower priority than Load 5.

Loads will only be added back one at a time. The higher priority loads will be added back based on the overall ordering described above if they have the same priority setting. All loads of a given priority setting will be added back before loads of a lower priority setting number will be added. For example, if there are three loads configured with priority setting of 1 and one load with priority setting of 2, all three priority 1 loads will be added before the priority 2 load is added.

Multiple loads with the same priority setting will time to shed concurrently when either of the shed inputs is true. Multiple loads assigned to the same priority setting may therefore be shed simultaneously if their shed delays are the same. As an example, two priority 1 loads with a shed delay of 0.5 seconds will shed at the same time. However, given a priority 1 load with a shed delay of 0.5 seconds and another priority 1 load with a shed delay of 0.8 seconds, the first load will shed after 0.5 seconds and the next will shed 0.3 seconds later. The overall time to shed for the second load will be 0.8 seconds.

As mentioned above, the first load will shed immediately on the rising edge of the shed input. If multiple loads have the same priority setting, only the first lowest priority, based on the overall priority described above, will be immediately shed and the others will time normally until they are shed.

The Load Add function will add only one load at a time, and the load add timer will time only for the load being considered for addition. Multiple loads with the same priority will not time concurrently for addition, the timer will be active for one load only. Even though loads with the same priority time concurrently for shedding, they will not time concurrently for addition.

Load Management Examples

Example 1: Load Management Based on Generation Capacity

Consider a system that has six loads of 400 kW each.

The facility has four natural gas generators of 800 kW because even though three machines could run the loads they value the redundancy that a fourth machine provides. With four machines running the system the machines are loaded to 0.75 per unit. When only three machines are present, they are 100% loaded. The facility avoids running the machines fully loaded for any length of time because achievable power output sometimes varies depending on gas supply. Thus, they set load shed to start occurring when per unit load is greater than 0.85 and they employ the shed fast feature if per unit load exceeds 0.95. When adding loads they desire a bias of 120 kW to prevent any machine from being fully loaded for any length of time as the system comes up. The parameters for load shedding are defined in Table 1.

Load	Priority	Shed Delay	Shed Fast Delay	Add delay	KW
Load 1	1	30	5	5	400
Load 2	2	30	5	10	400
Load 3	3	30	5	10	400
Load 4	4	30	5	20	400
Load 5	5	30	5	20	400
Load 6	6	30	5	30	400

Table 1 - Parameters for Load Shedding

The Add Reserve kW is set for 120 kW.

Suppose the system is normally driven by utility. If the utility fails, all the loads are tripped off line. The generators are all started at the same time. Load shed can be employed to add the loads to the generators

one at a time to avoid large block loads as the system is brought on line.

Logic (Figure 2) can be used to drive the actual Load outputs that close the loads using the Load Shed Priority N Enabled logic status inputs driven by the load shedding function when the generators are running or to close the loads when they are driven from utility power.

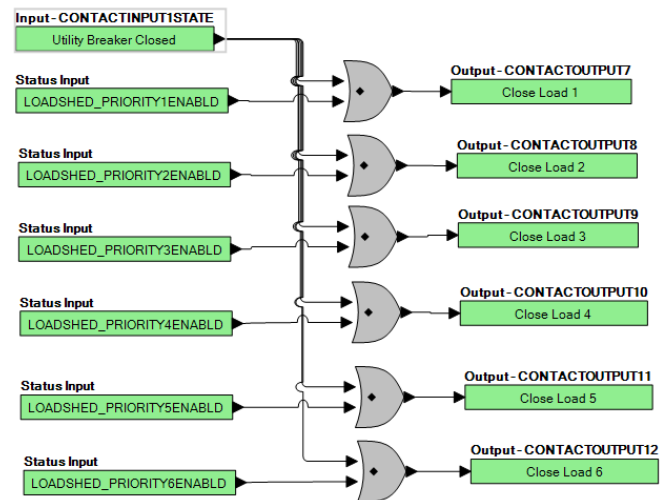

Figure 2 - Logic

Configurable protection can be used to set criteria for the load Shed. Configurable Protection 1 can be set to use a parameter of per unit load. Over Threshold 1 is set for 0.85 and Over Threshold 2 is set for 0.95. See Figure 3.

Another configurable protection can be used to set a threshold to indicate no units are on line. See Figure 4.

The screenshot shows the configuration interface for 'Configurable Protection #1'. It includes the following fields and settings:

- Label Text:** CnfPrt 1
- Operator:** None
- Arming Delay (s):** 0
- Parameter 1:**
 - Parameter Selection: Watt Demand per unit
 - Scale Factor: 1.00
 - Offset: 0.00
- Parameter 2:**
 - Parameter Selection: No Parameter Selected
 - Scale Factor: 1.00
 - Offset: 0.00
- Hysteresis (%):** 2.0
- Alternate Frequency Scale Factor:** 1.000
- Voltage Low Line Scale Factor:** 1.000
- Current Low Line Scale Factor:** 1.000
- Threshold #1:**
 - Mode: Over
 - Threshold: 0.85
 - Activation Delay (s): 0
 - Alarm Configuration: Status Only
- Threshold #2:**
 - Mode: Over
 - Threshold: 0.95
 - Activation Delay (s): 0
 - Alarm Configuration: Status Only
- Threshold #3:** (Empty)

Figure 3 - Configurable Protection #1

Configurable Protection #2

Label Text Units On Line	Operator None	Arming Delay (s) 0
Parameter 1 Parameter Selection Number of units online	Parameter 2 Parameter Selection No Parameter Selected	Hysteresis (%) 2.0
Scale Factor 1.00	Scale Factor 1.00	Alternate Frequency Scale Factor 1.000
Offset 0.00	Offset 0.00	Voltage Low Line Scale Factor 1.000
		Current Low Line Scale Factor 1.000

Threshold #1

Mode Under	Threshold 0.50	Activation Delay (s) 1	Alarm Configuration Status Only
---------------	-------------------	---------------------------	------------------------------------

Figure 4 - Configurable Protection #2

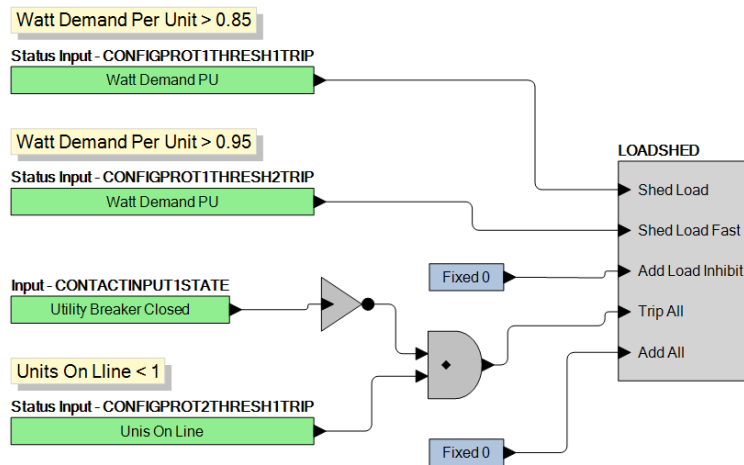

Figure 5 - Example Logic

The Configurable Protection 1 Over Thresholds are used to drive the Shed Load inputs on the Load Shedding logic element. Configurable Protection 2 Under Threshold can be used to trip all loads off if the utility breaker is open and no generators are running. Example logic is shown in Figure 5.

An operation summary of this system follows:

- When on utility power, all loads are on line.
- When the utility fails and no generators are running, all loads are tripped off line.
- Once generators are up and running, the loads are added on a priority basis at time intervals specified by the load add settings in the load shed function.
- If a generator goes down while the system is on generator power, load shed will trip loads off line in priority order based on the shed delay settings. This continues until the available generators can power all the remaining online loads with a per-unit kW demand less than 0.85.

Example 2: Load Management of Two Generator Systems Connected Across a Tie Breaker

Consider a system where two systems of generators and loads can be connected by a tie breaker. When the tie breaker is open, the two systems may act independently for load management. However, if the tie breaker is closed, there is one large system of generators and loads. Measures must be taken to prevent each independent system from adding loads in a manner that could overwhelm the available on-line generation capacity.

In the example below, the GGB1 controller may be configured to manage PL1 loads and the GGB2 controller may be configured to manage PL2 loads. Let us suppose for simplicity that the GGB1 system and the GGB 2 systems are identical with the loads and priorities the same as those in Example 1. Load additions to the two systems must be coordinated so that they do not both add loads at the same time, possibly overloading the online generation capacity.

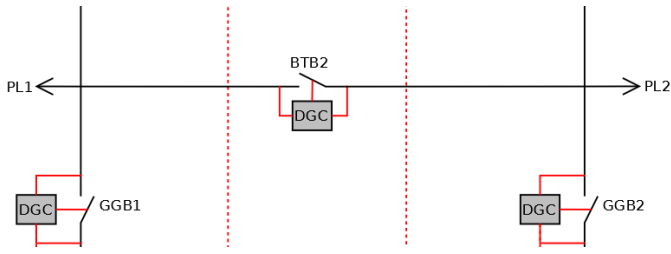

Figure 6 - GCB1 and GCB2 Controllers

One approach might be to set the add delays differently in the two systems. In System 1, the load add delays could be set to 5, 35, 65, 95, 125, and 155 seconds. In System 2, the delays could be set to 20, 50, 80, 110, 140, and 160 seconds. This would cause system 1 to add a load, then system 2 would add one 15 seconds later, back to system 1 adding a load 15 seconds after that, etc. The result is that the systems would alternate additions at 15-second intervals, starting with system 1. While this could achieve good load coordination while the tie breaker is closed, when the tie breaker is open and the systems are independent, we may be adding the loads more slowly in the individual systems because of the longer delays that were set to coordinate the two systems.

Another option for coordinating load addition of the two systems is to use Add Reserve Bias settings, which are engaged through the Load Shed Bias Enable logic

elements based on load conditions across the tie breaker. These could be driven by broadcast logic elements from the GGB1 controller to the GGB2 controller.

Suppose we want the GGB1 loads to close before the GGB2 loads in the event of limited generator availability. We could add load bias levels to the GGB2 controller based on the load status in the GGB1 controller. Example logic is shown below.

First, set Bias Enable 1 through 6 in the GGB2 controller to 100 kW. See Figure 7.

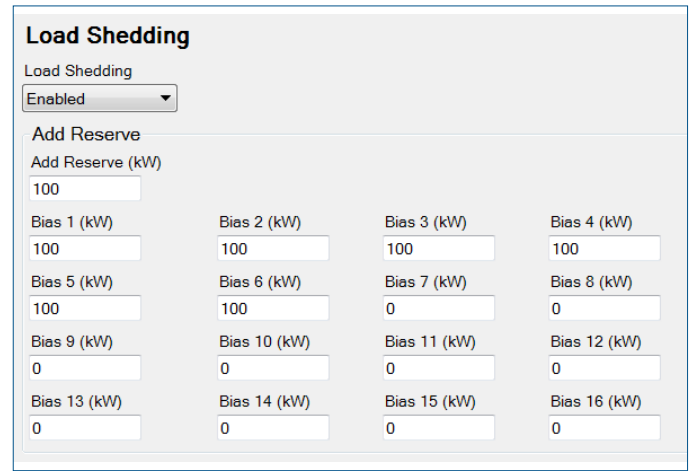

Figure 7 - Load Shedding Settings

Second, drive Broadcast Logic Elements in the GGB1 controller based on load status. See Figure 8.

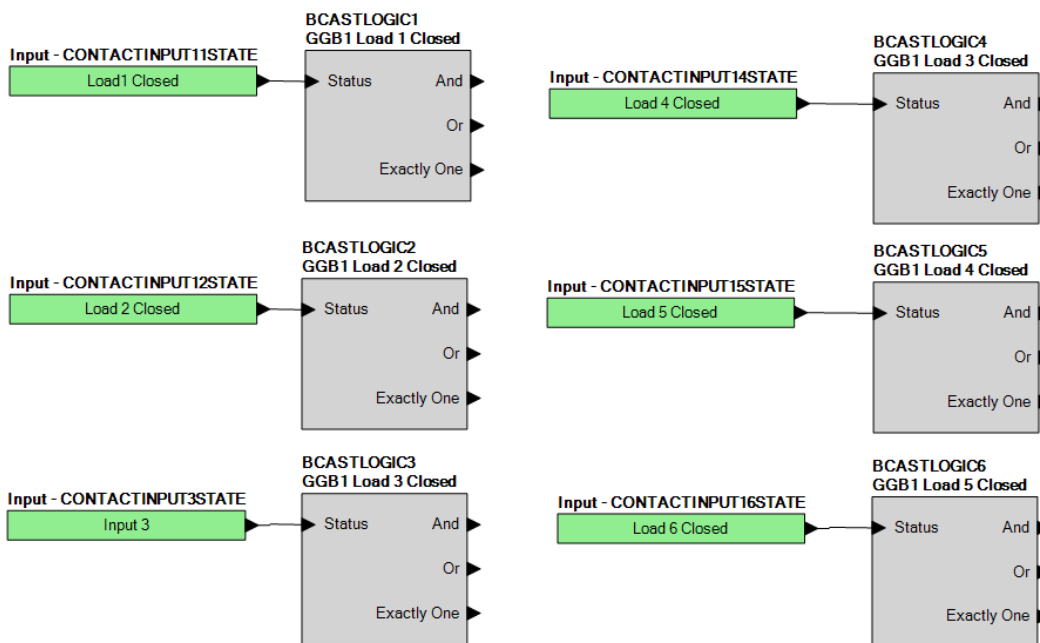

Figure 8 - Broadcast Logic Elements in GGB1

Third, use the Broadcast Logic Elements to drive the Add Bias logic elements in the GGB2 controller for each GGB1 input that is not closed. See Figure 9.

Now the system is configured such that if all machines are commanded to start at the same time, the GGB1 controllers will add GGB1 loads as soon as the on line generator capacity is sufficient for GGB1 loads only. The

logic driving the Load Shed Bias Enables configures the GGB2 controller so that it will not add GGB2 loads until there is enough capacity to cover the kW required for the next GGB2 load to add plus the GGB1 loads that are not yet closed. This ensures coordination of load addition between the GGB1 controller and the GGB2 controller on system startup.

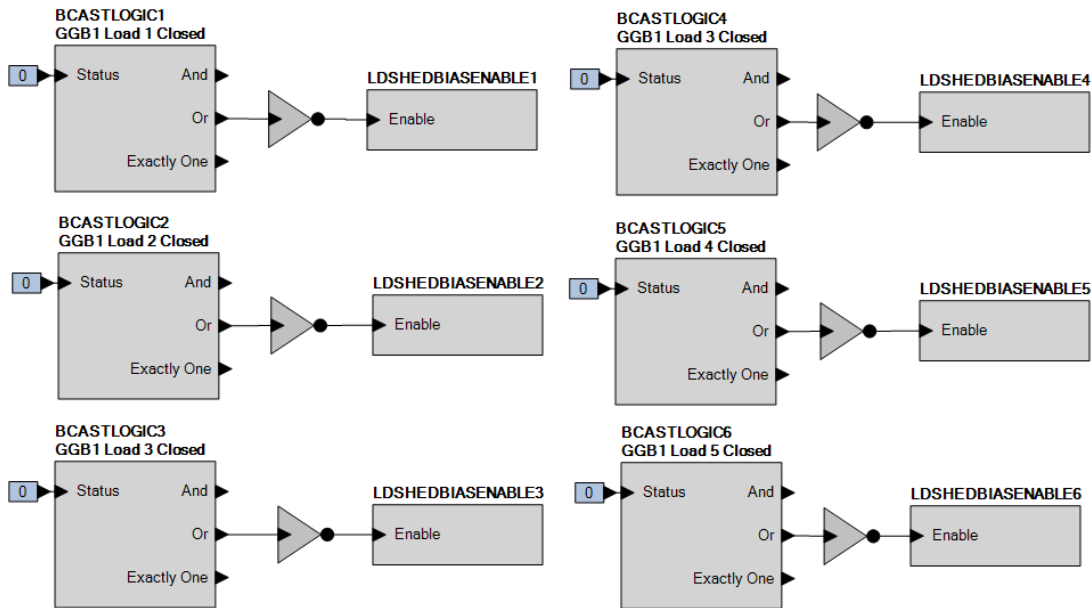

Figure 9 - Add Bias Logic Elements in GGB2

Example 3: Coordinating Transition between Power Systems

Consider an example of a cargo ship that hauls critical and noncritical refrigerated cargo, along with bulk cargo, and variable crew size so there are two crew quarter areas. The loads and prioritization are defined in Table 2.

Load	Priority	KW	Shed Delay	Shed Fast Delay	Add Delay
Navigation and Communication	1	250	30	5	5
Critical Refrigerated cargo	2	300	30	5	30
Crew Quarters 1	3	50	30	5	30
Crew Quarters 2	4	150	30	5	30
Noncritical Refrigerated cargo	5	900	30	5	30
Bulk Cargo	6	200	30	5	30

Table 2 - Loads and Prioritization

In normal operation, the total of all loads is 1,850 kW. The generators are four units of 800 kW each giving the system some level of redundancy since three generators can power the load. The add reserve is set to 300 kW. Demand Start Stop and generator sequencing are employed to use three generators to power the system, allowing the fourth to sequence off when not needed.

In a black start situation, all four generators are commanded to start, and then Load Shed will add the loads as generator capacity comes online.

When the ship is at sea, it relies on generator power, but in port, the ship is powered by shore power. When transferring from ship to shore power, or vice versa, it is desired to remove all loads other than the top priority load which is Navigation and Communication in order to minimize current through the ship to shore tie

breaker when transitions occur. While closed transitions are preferred, it is assumed that some shore power installations may require open transitions. Because of this, the system load is reduced to all but the most critical loads during power transitions to minimize the level of current through the ship to shore breaker when the transition occurs.

When the time comes to shed load down to the last, highest priority load, the load shedding function can be used to shed the loads in an orderly manner.

Once the transition to shore power has been accomplished, the Load Shed Add All input can be set to ON to get all loads connected to shore power.

A Logic example is shown in Figure 10.

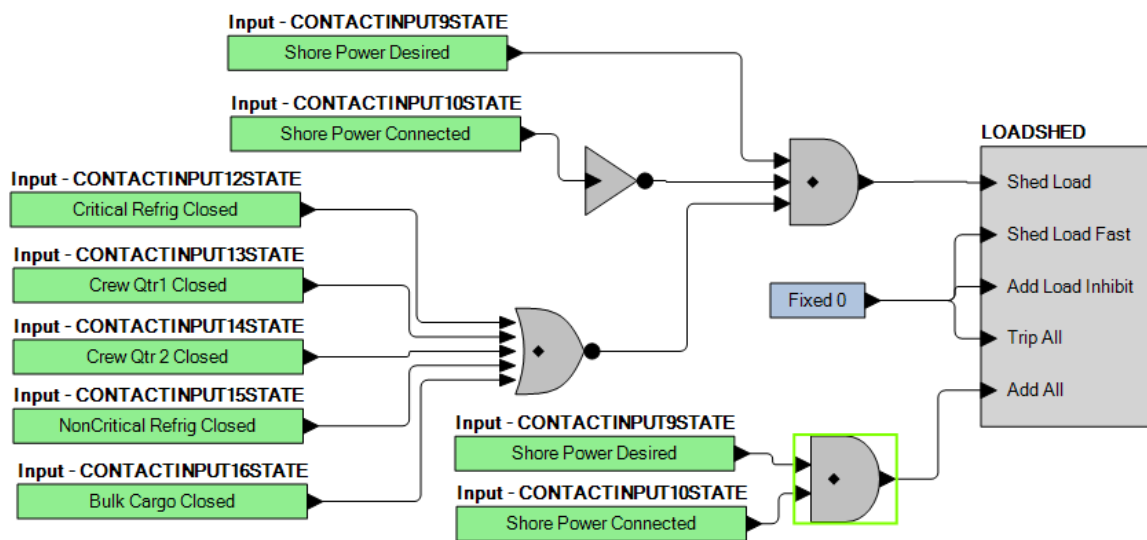
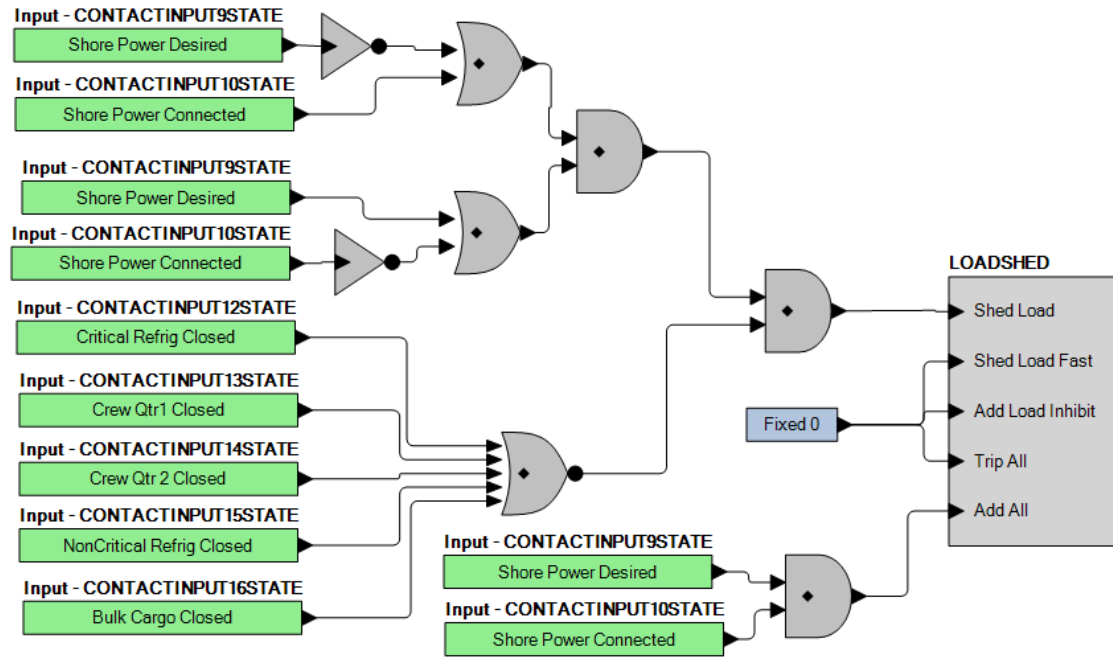

Figure 10 - Logic Example

With some additional logic, we could use Load Shedding to trip off all of the loads except the highest priority load when it is desired to go back to ship power. When it is desired to go back to ship power (indicated by the removal of the Shore Power Desired Input) and the shore breaker is closed, the Shed Load input can be driven to initiate the load shed process again. The above example is shown again in Figure 11 (next page) with the additional logic implemented. Once the transition to shore power has been accomplished, the Load Shed Add All input can be set to ON to get all loads connected to shore power.



This can be simplified somewhat. The set of gates below actually implement an exclusive OR (denoted XOR). See Figure 12 to the right.

Since these gates implement an XOR, the logic can be simplified to that shown in Figure 13 below.

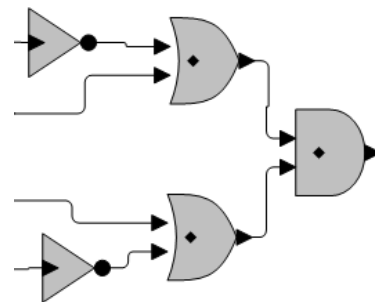

Figure 12 - Logic Gates

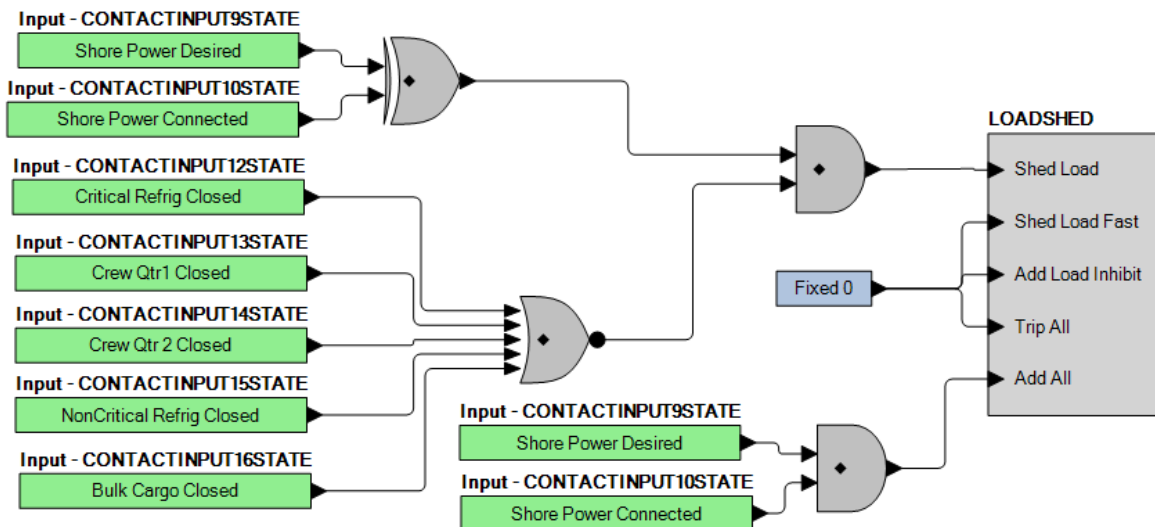

Figure 13 - Example Logic

Example 4: Load Management with Multiple Load Prioritization Schemes

There may be cases where it would be beneficial to employ differing load priorities based on different system conditions. This section offers an example of how to implement such a scenario with two different prioritization schemes.

Using the ship power scenario in the previous example, perhaps under different cargo conditions, there may not be a need for Critical Refrigeration and possibly

a smaller crew so that Crew Quarters 2 power is not needed. This alternate prioritization scheme is defined in Table 3.

In the Alternate Prioritization Scheme, Critical Refrigerated Cargo and Crew Quarters 2 are the lowest priority loads.

When implementing multiple prioritization schemes, a unique load number must be assigned to each load in the Load Shed priority scheme. An example of combining the two schemes above into to a combined Prioritization Scheme is presented in Tables 4 and 5.

Alternate Priority Scheme with No critical refrigerated cargo and reduced crew:

Load	Priority	KW	Shed Delay	Shed Fast Delay	Add Delay
Navigation and Communication	1	250	30	5	30
Crew Quarters 1	2	50	30	5	30
Noncritical Refrigerated cargo	3	900	30	5	30
Bulk Cargo	4	200	30	5	30
Critical Refrigerated cargo	5	25	30	5	30
Crew Quarters 2	6	5	30	5	30

Table 3 - Alternate Priority Scheme

Primary Prioritization Scheme

Load Name	Load Shed Load Number	Priority	KW	Shed Delay	Shed Fast Delay	Add Delay
Navigation and Communication	Load 1	1	250	30	5	30
Critical Refrigerated cargo	Load 2	2	300	30	5	30
Crew Quarters 1	Load 3	3	50	30	5	30
Crew Quarters 2	Load 4	4	150	30	5	30
Noncritical Refrigerated cargo	Load 5	5	900	30	5	30
Bulk Cargo	Load 6	6	200	30	5	30

Table 4 - Primary Prioritization Scheme

Alternate Prioritization Scheme

Load Name	Load Shed Load Number	Priority	KW	Shed Delay	Shed Fast Delay	Add Delay
Navigation and Communication	Load 7	1	250	30	5	30
Crew Quarters 1	Load 8	2	50	30	5	30
Noncritical Refrigerated cargo	Load 9	3	900	30	5	30
Bulk Cargo	Load 10	4	200	30	5	30
Critical Refrigerated cargo	Load 11	5	25	30	5	30
Crew Quarters 2	Load 12	6	5	30	5	30

Table 5 - Alternate Prioritization Scheme

The logic in Figure 14 causes loads 1 through 6 to shed when the Alternate Prioritization Scheme Select input is true, as well as causing loads 7 through 12 to shed when the Alternate Prioritization Scheme Select input is false.

Then, the LOADSHED_PRIORITYNENABLED status inputs from each scheme for a given load are OR'd together to close the output to close the actual load to the bus. Example logic is shown in Figure 15.

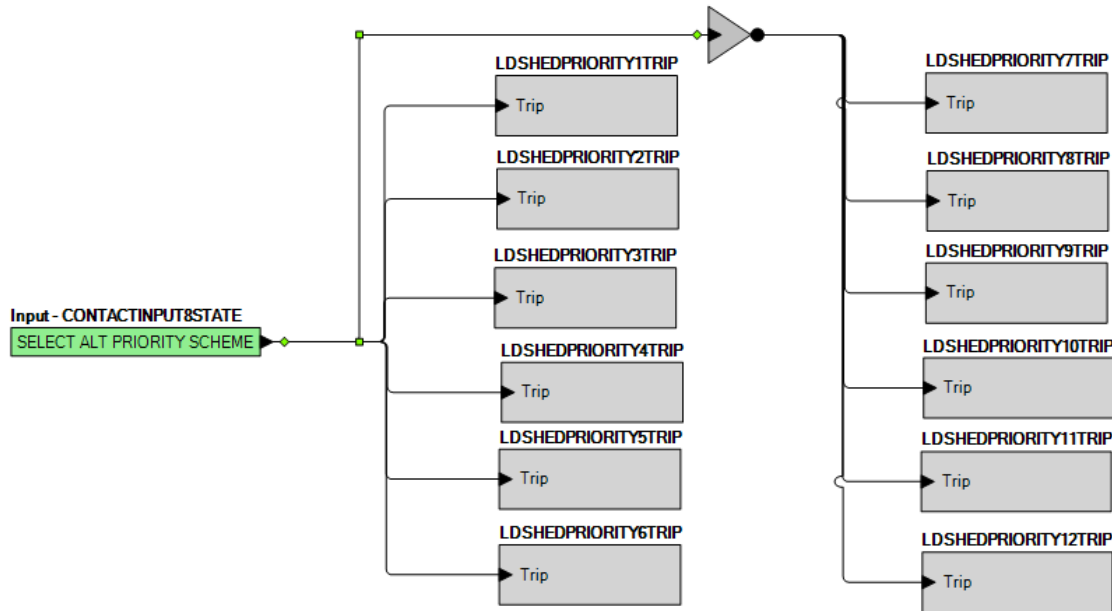

Figure 14 - Example Logic

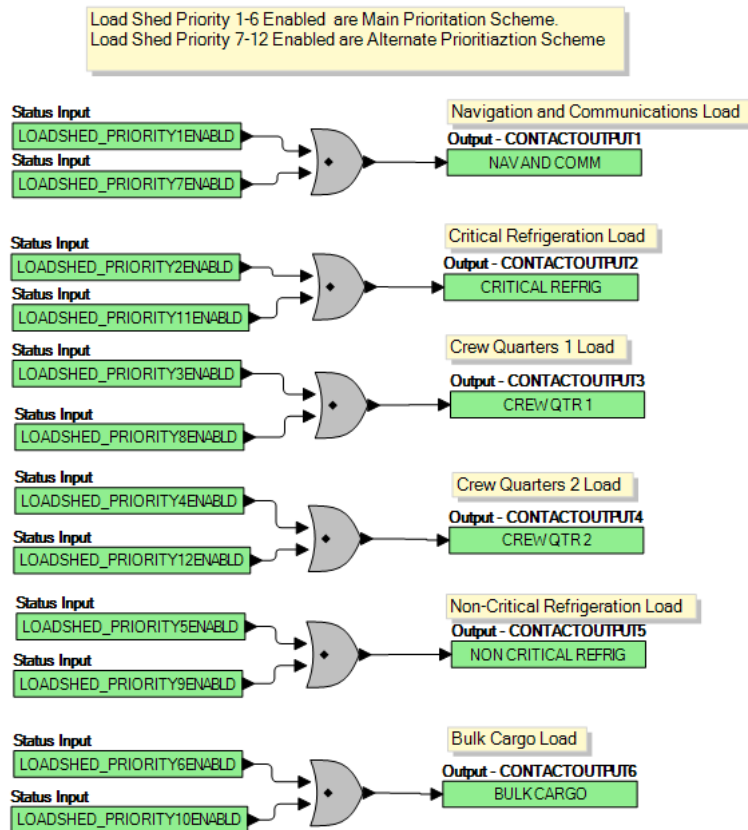

Figure 15 - Example Logic

Coupling this prioritization scheme with logic controlling generator start and when to shed load implements a priority scheme with Main and Alternate priority levels. Examples of logic to control when to start the generators and when to shed load have been presented in the preceding paragraphs and will not be repeated for this particular example.

For More Information

For further questions, contact Basler Electric Technical Support at 618-654-2341 or visit www.basler.com/support. For additional information including more application notes, product bulletins, instruction manuals, and technical papers, visit www.basler.com.



Highland, Illinois USA
Tel +1 618.654.2341
Fax +1 618.654.2351
email: info@basler.com

Suzhou, P.R. China
Tel +86 512.8227.2888
Fax +86 512.8227.2887
email: chinainfo@basler.com

