

Application Note

Phase Plot Compensator—A New Tuning Aid for Power System Stabilizer Implementation

Basler’s DECS controllers have a new power system stabilizer (PSS) feature: the phase plot compensator.

This feature enhances the ability to tune the phase compensation filters (T1–T8, see Figure 4) in the PSS of a Basler DECS digital excitation controller. It is available in the operating software of the DECS-2100, DECS-450, DECS-250, and DECS-250N. Independent power producers (IPPs), electric utilities, and power plants utilizing power system stabilizers can benefit from this tool provided in BESTCOMSPPlus®, and BESTCOMS™Pro for validating the tuning filters in the power system stabilizer.

Power System Stabilizer Application

Power system stabilizers are required by NERC (North American Electric Reliability Corporation) on machines in the Western United States, but not limited. The criteria for PSS application is as follows:

- Generator must be 25 MVA or above
- Power plant has a total aggregate power of 75 MVA or more
- Machine is one transformer removed from the transmission line
- Operating transmission voltage is 100 kV



Figure 1 - Voltage weak systems are susceptible to power system instability

Pole Slip Concerns

A PSS addresses power oscillations that occur on voltage-weak systems following a system disturbance (Figures 1 and 2). If left unchecked, the rotor can become unstable and swing beyond a critical power angle, causing the rotor to slip a pole and possibly damage

the synchronous machine. A pole slip event relates to ac current being induced into the rotor, which is normally dc. The ac component of this induced current can be great enough to cause the net field current to become negative. This will cause the field current to flow out of the F+ terminal back toward the exciter. Therefore, when pole slip occurs, the poles of the stator no longer align with the rotor field poles within an acceptable power angle, out of phase. Most exciters do not have a path for reverse current flow and this causes extreme overvoltage. This overvoltage can burn the slip rings and damage the diodes on a brushless exciter, not to mention the violent reaction heard when it has occurred.

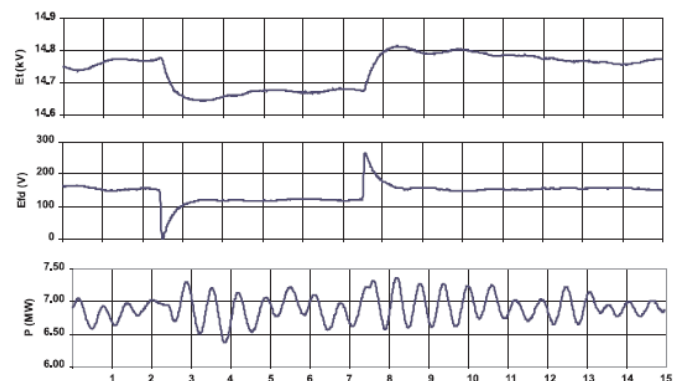

Figure 2 - Power system oscillations following a unit disturbance

During a voltage disturbance, the voltage regulator plays an important role in stabilizing the rotor. The voltage regulator responds immediately by increasing the field power to restore flux in the field. This restores the alignment (synchronizing torques) of the north and south poles between the stator and rotor.

However, there is an issue that occurs within the dynamics of the voltage regulator sensing circuits. Filters within these circuits tend to create a lag. This lag, combined with the time constant of the generator field, can result in field excitation that is out of step with the maximum power swing of the rotor during a disturbance. In other words, the level of field excitation may be at a minimum when the rotor swing is at its maximum,

pushing the field excitation so that it is out of phase with the maximum power swing. Flux, which is related to the level of supplied excitation, acts as a dynamic brake on the rotor. Therefore, it is important to push excitation into the field at a time that coincides with the rotor being at its maximum swing to reduce the rotor swing. Because of the associated time lags, this phenomenon becomes readily apparent on voltage-weak systems. Here, a PSS is applied to stabilize the rotor quickly and provide nearly immediate damping to the power system. Figure 3 shows a dual input power system stabilizer that measures compensated speed and electrical power identified as the "Integral of Accelerating Power". The Lead/Lag blocks are used to compensate for the phase lag associated with the time lag of the voltage regulator filter and generator time constant.

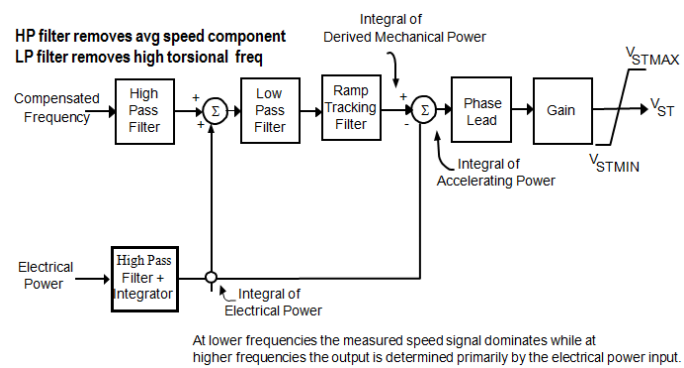

Figure 3 - Phase Lead block for compensation of voltage regulator phase lag

Configure		Control	Parameters	Output Limiter	
Primary	Secondary				
Low-Pass/Ramp Tracking				Rotor Freq Calculation	
0.00	T11 - Time Const.	0.50	Tr - Time Const.	0.000	Quadrature Xq
1.00	T12 - Time Const.	1	N - Num Exp.	1.00	Power Input
0.10	T13 - Time Const.	5	M - Den Exp.	1.00	Kpe
High-Pass Filtering/Integration				Phase Comp. - Time Constants	
1.00	Tw1 - Time Const.	1.00	Tw4 - Time Const.	1.000	T1 - 1st Phase Lead
1.00	Tw2 - Time Const.	1.00	H - Inertia	1.000	T2 - 1st Phase Lag
1.00	Tw3 - Time Const.			1.000	T3 - 2nd Phase Lead
Torsional Filters				1.000	T4 - 2nd Phase Lag
0.05	Zeta Num 1	0.05	Zeta Num 2	1.000	T5 - 3rd Phase Lead
0.25	Zeta Den 1	0.25	Zeta Den 2	1.000	T6 - 3rd Phase Lag
42.05	Wn 1	42.05	Wn 2	1.000	T7 - 4th Phase Lead
				1.000	T8 - 4th Phase Lag

Figure 4- Lead-lag filters used to provide PSS compensation

Generator Frequency Response, Lead/Lag Phase Margins for PSS Tuning

To determine the time lag of the voltage regulator and synchronous machine, frequency response testing is performed while the generator is operating. With the breaker closed and the generator operating at approximately 25% real load, a small signal is applied into the voltage regulator summing point and the

generator output is measured. The sweep frequency begins at 0.1 hertz and ends at 3 hertz. Over this range, decibel (dB) and phase angle data are collected and displayed in a Bode plot (Figure 5). A critical frequency of 1 hertz is used to evaluate the voltage regulator time lag relative to the phase angle difference between the incoming signal and the generator output. With faster voltage regulator response, less phase lag will be observed at 1 hertz. Once the phase lag is determined, the appropriate compensation can be applied to filters T1–T8 of the power system stabilizer (Figure 4).

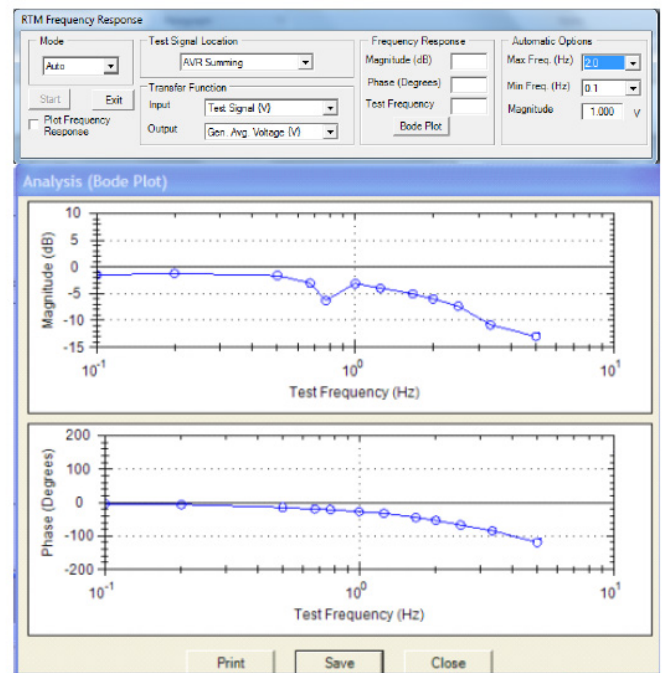

Figure 5 - Bode plot showing phase lag of 25 degrees at 1 hertz

Proper phase compensation with lead-lag filters is required to effectively dampen power oscillations. In general, a compensated phase is required to be within 30 degrees of the zero-degree target for most of the range of interest. No more than 45 degrees of lag should be observed at 3 hertz, which is above the local mode frequency. Basler's phase plot compensator enables plotting of the lead-lag time constants of phase compensation (Figure 4) offering convenience of adjustments as needed with immediate validation. Here, the frequency response of the transfer function of V_t/V_{ref} is performed and the measured gain and phase are displayed as the necessary phase shift to be obtained through the lead-lag filter. Four lead-lag filters are available to best shape the gain and phase characteristics over a wider range of frequencies and meet performance targets. After selecting time constants T1–T8, the gain and phase to be compensated by the lead-lag filters are determined and the inverse

of the frequency response is displayed in red by clicking the Plot Phase Compensation button to demonstrate the compensation provided. With proper phase compensation, the difference between these two curves should be close to zero degrees. Figure 6a illustrates poor compensation of the T1-T8 filters selection. Notice that at 1 hertz, a 50-degree phase difference between the blue curve (Frequency Response) and the red graph

(Filter Compensation), which demonstrates poor PSS performance in Figure 6b when a 2% voltage step has been initiated. Note, however, in Figure 7a that with proper selection of the T1-T8 filters results in little phase difference between the blue and red curve. Power system oscillation is immediately damped after a 2% voltage step has been initiated as shown in Figure 7b.

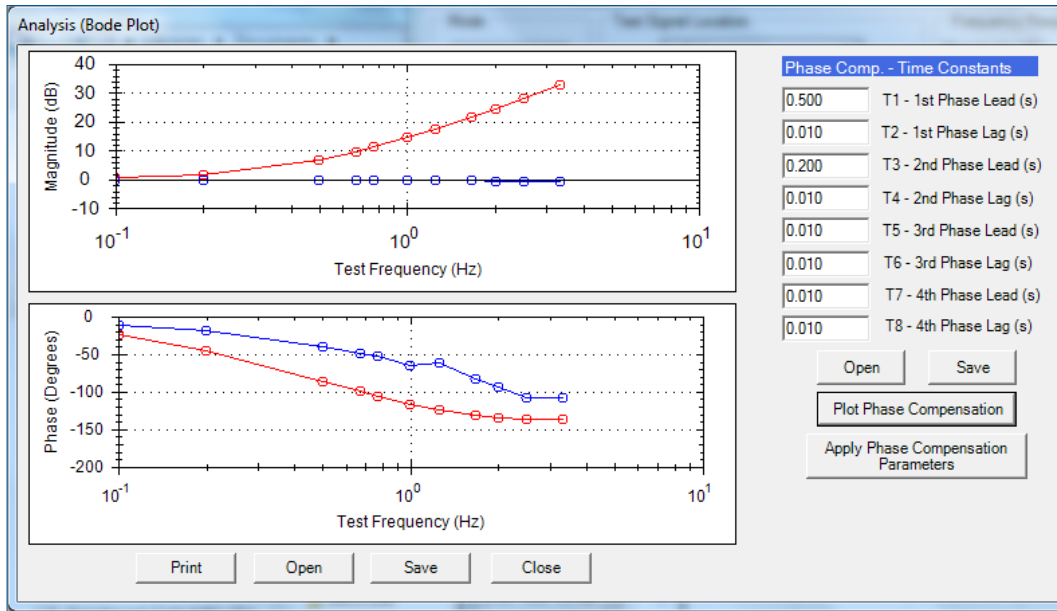

Figure 6a - Poor filter tuning, 50-degree phase margin at 1 Hz, which is unacceptable

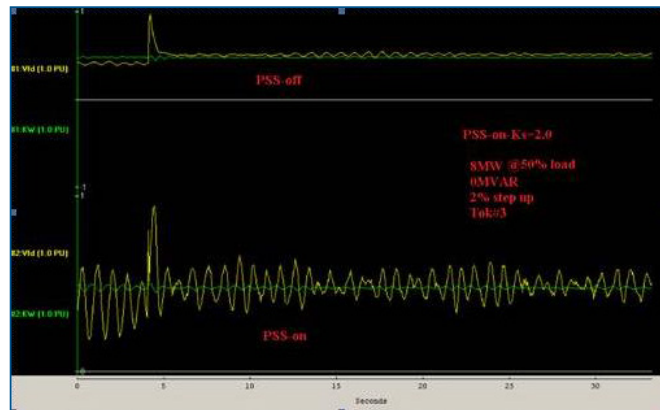

Figure 6b - 2% voltage step change demonstrating poor response from the Lead/Lag filter tuning in Figure 6a

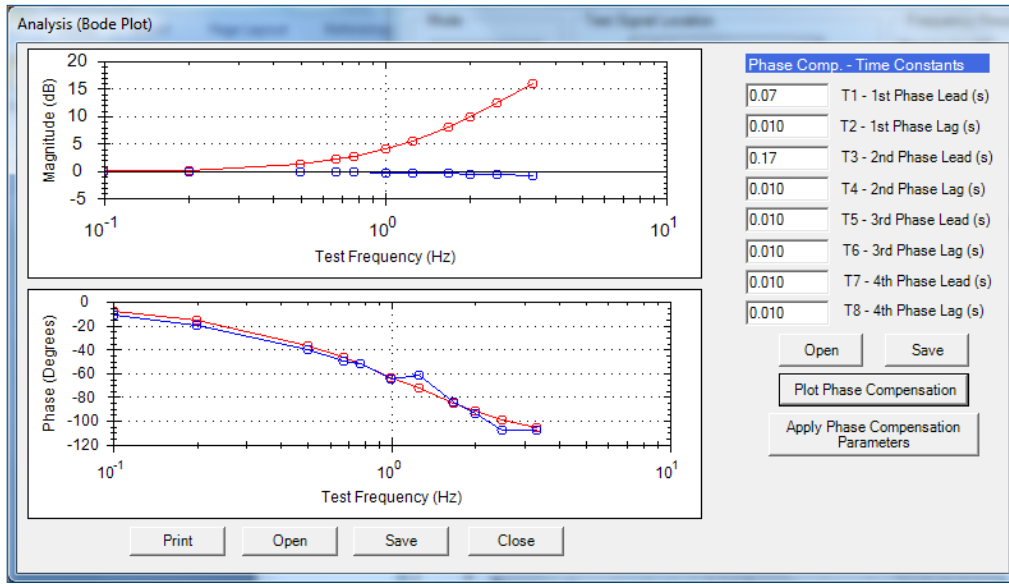

Figure 7a - Compensated phase for voltage regulator lag (Note that the red plot shows optimal compensation.)



Figure 7b - A properly tuned PSS exhibits immediate damping after a small signal disturbance

Beyond determining the needed compensation by filters T1-T8, washout filters need to be selected to remove steady-state speed deviation as well as two significant tests to determine the Quadrature Reactance (X_q) and the Inertia (H). The quadrature reactance is obtained by performing a 25% underexcited, reactive-load rejection test and recording the generator voltage decay. The inertia is obtained by doing a 10% real-power load rejection test and measuring the time in seconds versus frequency change.

As Basler continues to invest in new technology, new tools are developed to assist in tuning and validating the power system stabilizer for optimum control and performance. For additional information about PSS tuning, see the Basler technical paper entitled *Elements of Tuning a Power System Stabilizer for NERC Compliance*.