

# Application Note

## Basler Offers Integrated Retrofit Packages for Gas Turbines

**Owners of gas turbine driven generators built in the 1960s and 1970s face the increasingly frustrating challenge of maintaining original equipment excitation systems that are rapidly approaching obsolescence.**

Parts and service are harder to find, while the costs of generation downtime continue to increase. These problems increasingly affect the owners of Pratt & Whitney Single/Twin Pacs, frequently provided with Electric Machinery generators, and owners of Westinghouse 251/501 gas turbines and General Electric Frame 5 gas turbines supplied with proprietary voltage regulator or excitation systems.



Figure 1: Combustion Turbine Generator

Basler Electric offers integrated regulator/exciter systems that functionally replace the original OEM equipment and, in many cases, fit into existing equipment cubicles. The packages are pre-designed systems that are factory tested and ready for installation, designed to interface with existing switches and meters for integration into the existing hardware with minimal modification to the original control philosophy.

### P & W Twin Pac Replacement Package

Figure 2 shows the original excitation system supplied with a 1970s vintage P & W Twin Pac generator. The regulator system included an analog voltage regulator that used

manual voltage control for backup. Motor-operated potentiometers were used with the voltage regulator as manual control for remote voltage set point adjustment, while minimum and maximum excitation limiters were included with the voltage regulator. The panels were installed in “standard” cubicles.

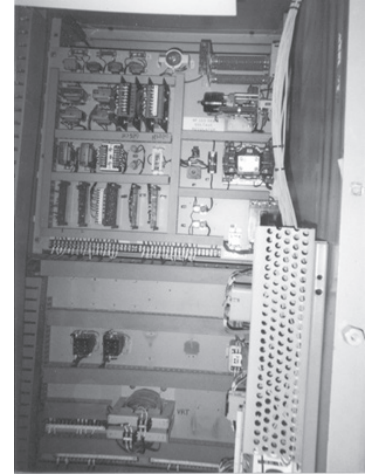

Figure 2: Excitation System for P&W Twin Pac

The replacement Basler voltage regulator system shown in Figure 3 provides all of the functions of the OEM equipment and more, with easy interconnections to existing wiring, facilitating quick field installation, checkout and startup.

For reliability concerns, the conventional practice for the original analog excitation system designs was to provide an automatic voltage regulator with a manually operated backup excitation system.

Now, with advances in digital technology, the preferred method for improved reliability is to have an excitation system with dual automatic voltage regulators as shown in Figure 3. Each DECS-250N regulator provides four operating modes: automatic voltage regulation, field current regulator for manual control, Var and Power Factor control modes.



Figure 3: Dual SGC-250N System Replacement for P&W Twin Pac

In addition, each regulator is complete with minimum and maximum excitation limiters, Volts/Hz or underfrequency limiter, and stator current limit. Many excitation-based protective functions with programmable output relays are built in. Protective functions include generator over and undervoltage, field overvoltage, field overcurrent, loss of

field and brushless exciter open or shorted diode detection. Oscillography and other software tools are included to easily perform step set point changes to assist in tuning the digital regulator, as well as performing other tests to accommodate generator compliance certification for NERC and power system model verification.

In accordance with North American Electric Reliability Corporation (NERC) regional or Independent System Operator guidelines, many generators with capacity of as little as 35 MVA are required to have power system stabilizers working in conjunction with the automatic voltage regulator. The DECS-250N includes the option for a power system stabilizer where required to comply with NERC. For these applications, a voltage regulator capable of providing both positive and negative field forcing voltage is necessary. For retrofit applications where a DECS-250N excitation system normally would be used, applications requiring power system stabilizers should use the DECS-250N negative forcing excitation system.

The system block diagram for the brushless excited generator is shown in Figure 4.

### GE Frame 5 Excitation Replacement

GE Frame 5 gas turbine generators manufactured in the early 1970s were likely to have an analog static excitation

system, called an SCT/PPT (Saturable Current Transformer/Power Potential Transformer). Although GE has declared this system obsolete because the old circuitry can cause problems, the SCT/PPTs magnetics are usually in fair condition despite their age. A modern upgrade retrofit solution is to use the DECS-450 excitation system controller and other necessary components installed on a pan chassis to replace the “front end” voltage regulator section and retain the original magnetic components. Excitation control is accomplished by applying a dc current into the control winding of the SCT. Usually, replacing the “front end” electronics is preferable because of the limited space in the excitation compartment of the gas turbine/generator package shown in Figure 5.

The DECS-450 potential source static excitation system may also replace the entire SCT/PPT static exciter, supplying excitation power directly into the main field of the GE Frame 5 slip ring machine.

DECS-450 static exciters are provided in NEMA 1 enclosures to replace the original enclosures and can be installed in approximately 8 to 10 working days. DECS-450 systems can be designed to meet the specific control and protection requirements of the site and supplied for either 50 or 60 hertz applications.

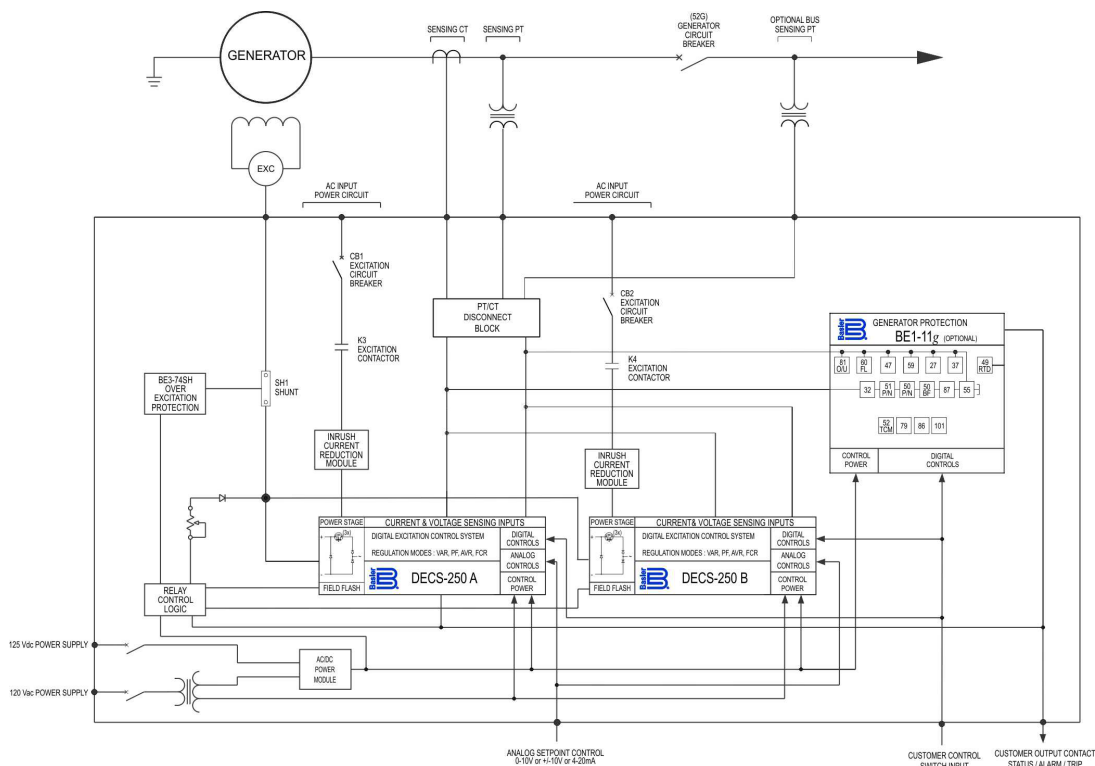

Figure 4: One-line Diagram for the SGC-250N

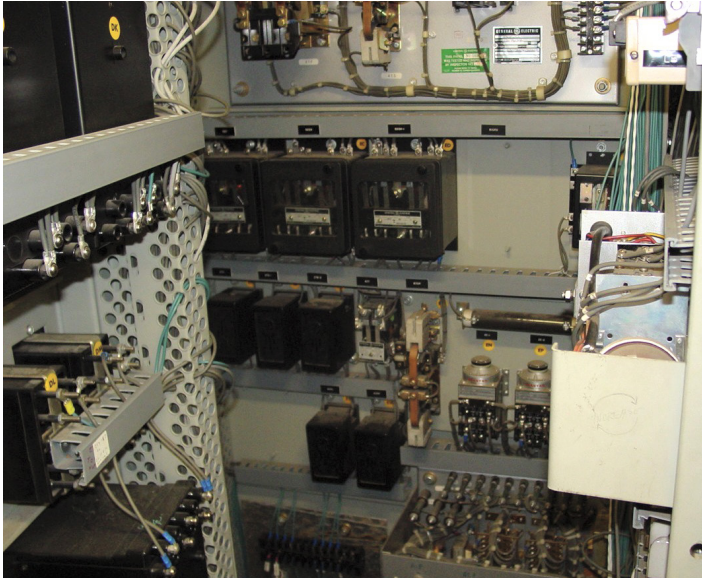

Figure 5: Original SCT/PPT Voltage Regulator Equipment

### Westinghouse 251/501 Retrofit Option

Owners of Westinghouse brushless excited 251/501 gas turbines with Powertrex/PRX voltage regulators could utilize the DECS-400 based voltage regulator system shown in Figures 7 and 8.

The DECS-450 excitation system provides the same feature rich functionality as the DECS-250N excitation system plus other functions including an integrated power system stabilizer, if required.

It is designed to fit into existing panel space. The system is powered from the existing 420 Hz PMG and provides positive and negative field forcing for optimal transient performance. The system is designed to interface with existing controls and instruments and provides 0.10% voltage regulation.

### To Learn More

Basler offers a variety of retrofit packages to assist in the efficient and cost effective upgrading/replacement of older systems. For more information on voltage regulator/excitation system retrofits for gas turbine generators or any other retrofit opportunities, consult the Basler factory at +1 618.654.2341.

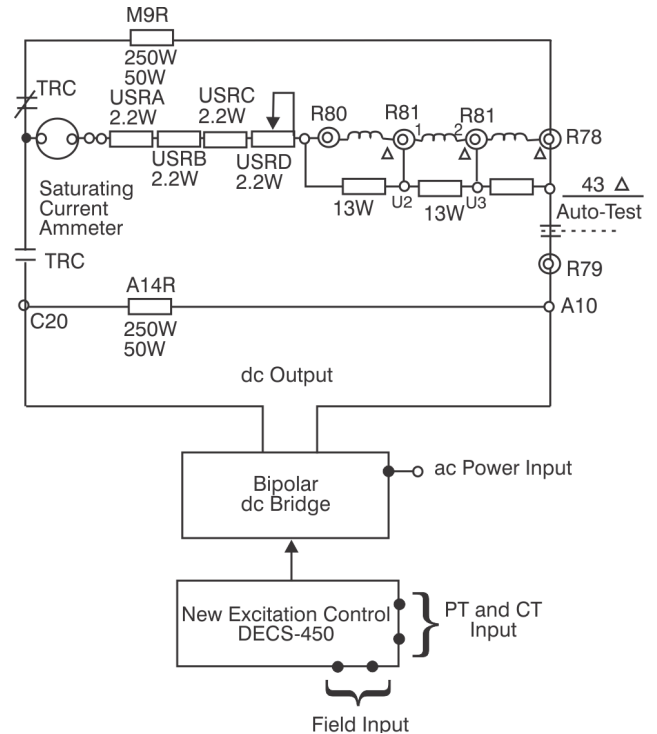

Figure 6: Block diagram of new excitation system interfacing with SCT control windings



Figure 7: DECS-400 Replacement of PRX 302 Voltage Regulator on Westinghouse 501 Generator



Figure 8: Basler Firing Circuit Chassis for Westinghouse Powertrex /PRX Voltage Regulator Retrofit

## DECS-250N and DECS-450 Features

- UL Recognized, CSA Qualified, CE Compliant
- Oscillography - 1,200 points, 6 programmable parameters, holds up to 6 records
- Meets ANSI C37.90.1 for Surge Withstand and Fast Transient
- Meets RFI (Radio Frequency Interference)
- Meets Conducted and Radiated Noise per IEC 60255-22-6 (Conducted) & 60255-22-3 (Radiated)
- Field current or field voltage regulator for standby mode and NERC testing
- Operating Temperature Range -40° to 60°C
- Voltage Regulation - 0.1% Accuracy for the DECS-450 and 0.2% Accuracy for the DECS-250N
- DECS-250N can be used for systems whose fields do not exceed 20 Adc continuous, DECS-450 for all systems greater than 20 Adc continuous
- Var/Power Factor Controller
- Automatic Nulling - Nulling between operating modes and redundant DECS
- Selectable Underfrequency or Volts/Hertz Ratio Limiter
- Minimum Excitation Limiter - Flexible 5 point map on real/ reactive power axis or Internal generated UEL curve
- Maximum Excitation Limiter
- Var Limiter
- Stator Current Limiter
- Dual PID Setting Groups - Allows for programmed changes in PID gain settings for use with Power System Stabilizer or alternate transmission systems
- Auto Tuning of the Voltage Regulator PID gains
- Auto Voltage Matching - Automatically matches generator voltage to bus voltage
- Auto Synchronizing (Device 25A) option
- Autotracking for bumpless transfer between Automatic Voltage Regulator (AVR), manual control, and Redundant Controller when included
- 3 Preposition Set points - Programmable for AVR, Manual, Var/PF Controller
- Reactive Droop or Line Drop Compensation, Network Reactive line sharing via Ethernet communications for multiple machine on a single bus
- Loss of Voltage Sensing - Transfers to manual control automatically due to loss of voltage sensing at the voltage regulator
- Sequence of events - stores 2,047 records
- Real time chart recorder, data logging including oscillography and sequence of event information for data capture up to six channels
- Built-in Dynamic Analyzer for measuring frequency response of generator and excitation system using Signal Generator
- Protection
  - Generator Overvoltage
  - Generator Undervoltage
  - Loss of Voltage Sensing
  - Field Overvoltage with Dual Settings Groups
  - Field Overcurrent with Dual Settings
  - Generator Overfrequency
  - Generator Underfrequency
  - Generator Reverse Power
  - Generator Loss of Excitation
  - Synch Check when 25A is disabled
- Exciter Diode Monitor for Brushless Exciters
- Generator Below 10Hz
- Volts per Hertz: coordinates with the V/Hz limiter function
- Loss of Field Isolation Transducer
- Control Power Input Failure
- Crowbar Activated
- Field Over Temperature
- Watchdog Timer: monitors the microprocessors and provides a trip contact if a microprocessor fault occurs
- Redundant Controller
- Field overvoltage, generator over/undervoltage, field overcurrent, and loss of field protections have dual set points selectable via programmable logic
- HMI Metering, Operating Screen - Metering, Control, Annunciation
- IRIG-B Time Synchronization stamp
- Generator Field Temperature Monitoring (Static Exciter)
- 5 Analog Transducers Outputs
- Optional Built-in Power System Stabilizer, Type 2A/2B/2C, Integral of Accelerating Power
- Phase Plot Compensator for Power System Stabilizer assisted tuning
- 6 SCR Bridge Rectifier
- RS-485
- Ethernet over Modbus® TCP
- BESTCOMSPPlus® common operating software to Basler Electric product family
- BESTlogic™Plus programmable logic
- Expandable Inputs and Outputs via remote modules

## DECS-250N and DECS-450 Auto Tuning

The DECS-250N and DECS-450 have a feature called PID auto tuning via BESTCOMSPi.us® operating software. Auto tuning is used during commissioning with the generator spinning. After initiation, the auto tuning feature is performed in less than a minute that will determine the PID gains for the generator. It accomplishes this with the spinning machine open circuited by performing number of voltage step changes to the generator output resulting in suggested gains. Additionally, the auto tuning will determine the machine Time Constants of the Exciter (te) (where applicable) and Generator (T'do"), which is required data for generator modeling. The PID auto tuning process speeds commissioning to enable the generator to become fully operational sooner to the system.

## DECS-250N and DECS-450 Phase Plot Compensator

Additionally, a Phase Plot Compensators is provided with the Dynamic Frequency Analyzer to assist in evaluating the Power System Stabilizer Lead/Lag time filters selected that are derived from the Frequency Response of the generator system. Proper compensation is required for all systems that require a Power System Stabilizer. See Figure 9. When the red and blue curves align in the Phase Lag graph, proper compensation is achieved and test validation is then required.

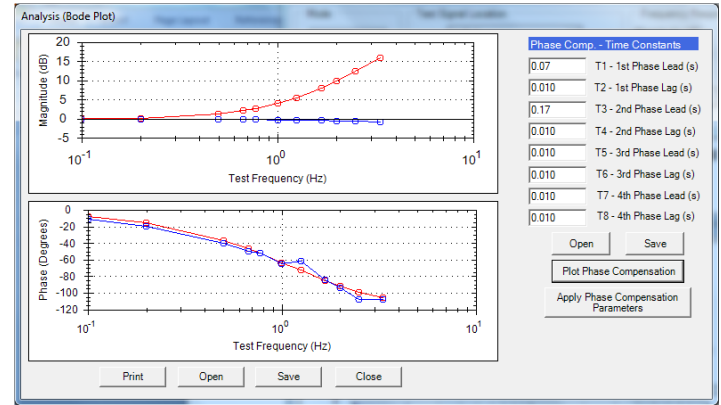

Figure 9: Frequency Response Results using Built-in Dynamic Analyzer

## BESTspace™

The DECS-250N and DECS-450 offer a setup commissioning tool in BESTCOMSPi.us operating software that allows one to set up preferred monitoring screens from the Metering Explorer. BESTspace allows one to save the file as a "default" and it will come up on the preferred screen every time BESTCOMSPi.us is opened. Valuable time saved during setup speeds the commissioning preparation time for startup. See Figure 10.

## For more information

For more information, call 618.654.2341 to consult with a Basler Excitation System Application Specialist or visit [www.basler.com](http://www.basler.com) to download a DECS-450 or DECS-250N product bulletin.

For technical papers on auto tuning and phase plot compensation visit [www.basler.com](http://www.basler.com).

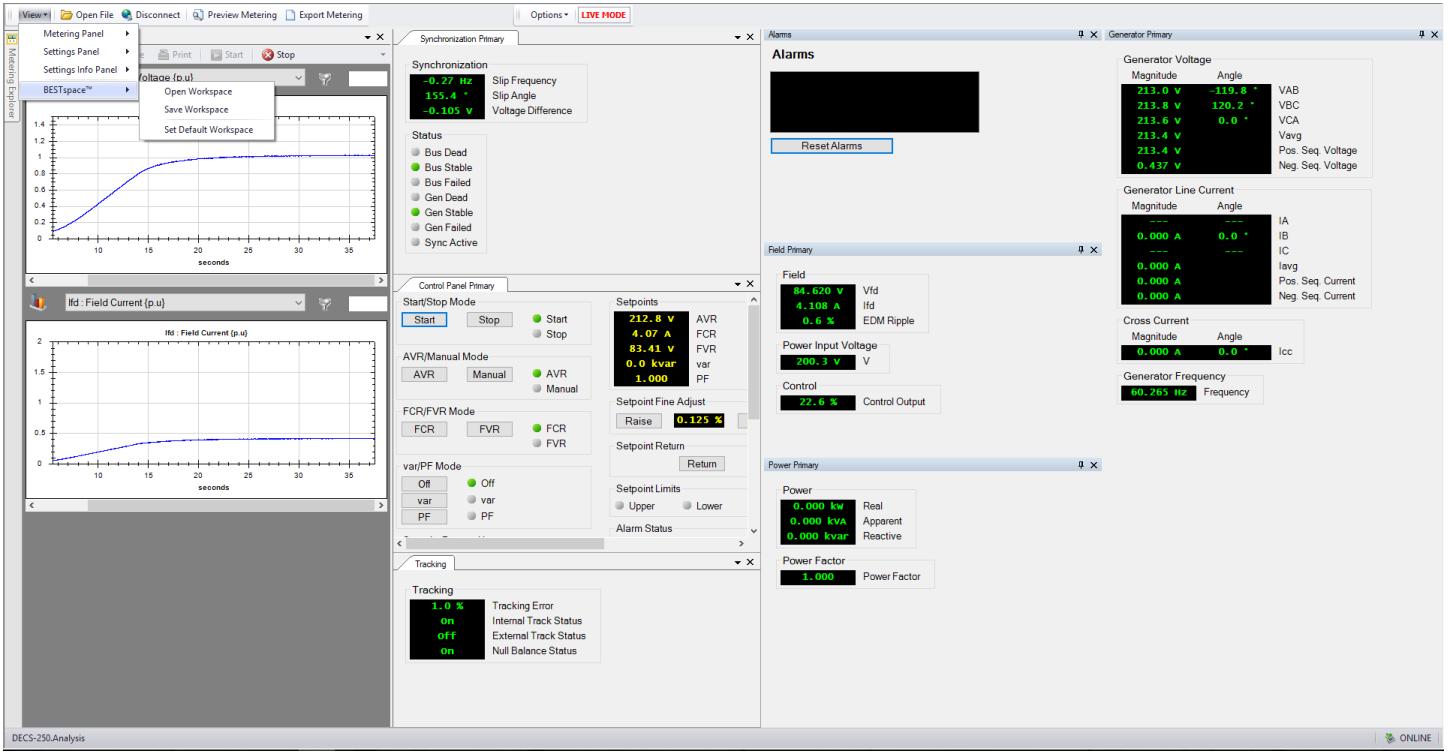

Figure 10: BESTspace